

## **Phonological analysis of word-final consonants in Akan**

Emmanuel Nicholas Abakah

Department of Linguistics  
Norwegian University of Science & Technology, Trondheim  
nanabakah@yahoo.co.uk

### **1. Introduction**

Phonological study of word-final consonants in Akan has not received adequate attention in the literature. However, scholars of Akan phonology seem to be divided on the number of consonants that occur in phonological representations of Akan morphemes. Schachter & Fromkin (1968), for instance, have posited /j, h, w, p, b, f, k, g, t, d, s/ as the consonantal constituents of the Akan systematic phonemes. Dolphyne (1988), Abakah (1993) and others have identified the following sixteen systematic consonantal phonemes /m, n, j, w, p, b, f, t, d, s, k, k<sup>w</sup>, g, g<sup>w</sup>, h, h<sup>w</sup>/, while Abakah (in preparation) has also posited that fourteen consonantal segments occur in phonological representations in Akan. Be that as it may, all the phonemic consonants that various scholars posit for the Akan language occur at word-initial and word-medial positions but not word-finally except for only four nonvowel sonorants [m, n, r, w], which can occur at word-final position in phonetic representations. In this paper, I discuss the distribution of the nonvowel sonorants in the three major dialects of Akan namely, Fante (Fa.), Asante (As.) and Akuapem (Ak.).

### **2 Distribution of Akan consonantal sonorants**

It is important to restate that all consonantal sonorants that occur word-finally in Akan occur at the lexical level of representation as penultimate segments, which redundantly constitute the onset of the word-final -CV# syllable whose V is specified as [+High] and, it can be either [CORONAL] or [DORSAL]. Their emergence at the phonetic surface as word-final segments is invariably the direct result of the delinking of the lexical postsonorant word-final [+High] vowel in question. I give the phonological analysis of the four consonants shortly but before then let us study

briefly Schachter & Fromkin's true and word-final consonants in Akan.

## 2.1 Schachter & Fromkin's (1968) word-final consonants in Akan

Schachter & Fromkin (1968: 35) have labeled /p, b, d, f, s, t, k, g/ as the 'true' consonants in Akan and argued that:

In dictionary matrices of Akan formatives, eight 'true' consonants (i.e. segments which are [+Consonantal, -Vocalic]) are needed to distinguish morphemes. All of these segments are redundantly [-Vocalic, -Low, -Nasal]

According to Schachter & Fromkin's (idem) definition of true consonants, all the word-final consonants, which I have identified in Akan, /m, n, r, w/, are not true consonants and therefore they do not occur in phonological representations. /m/ and /n/ are [+Consonantal, -Vocalic] but inasmuch as they also have [+Nasal] specification in their feature matrix, they are not 'true' consonants. /r/ is [+Consonantal] but it is also [+Vocalic] in the sense of Jakobsonian original binary/distinctive feature theory, which Schachter & Fromkin (1968) used for their analysis. Therefore /r/ is not a 'true' consonant. It is worth pointing out that in the feature geometry theory (developed by Clements 1985, Sagey 1986, McCarthy 1988, Odden 1991, Clements and Hume 1995, Gussenhoven and Jacobs 1998 and others), which addresses all the problems inherent in the distinctive feature theory, /r/ has no V-Place specification but C-Place [CORONAL] articulation. Hence, I assume in this article that /r/ has no V-Place articulation feature but is preassociated to C-Place [CORONAL] and is therefore redundantly an absolute [-Vocalic, +Consonantal] segment. Consequently, I presume in this article that if Schachter & Fromkin (1968) had done their work recently, during the era of feature geometry, they would have classified /r/ as true consonant, at least in some other language, even if not in Akan. /w/ is [-Vocalic] alright but its quality of being [-Consonantal] as well makes it an absolute candidate of non-true consonant. Therefore, on Schachter & Fromkin's (idem) terms, /m, n, r, w/ cannot be posited as underlying segments in Akan. They (idem: 52) accordingly derive all their word-final consonants from their set of 'true' consonants as follows:

It may be noted that while SqSC2 (Sequence Structure Condition) has constrained final non-vocalic segments of primary syllables to the set of stop consonants, none of these consonants is left intact by the P-rules in this position. Specifically,

$$/p/ \rightarrow [w], \quad /b/ \rightarrow [m]$$

/t/ → [r],                    /d/ → [n]  
 /k/ → [ʔ],                    /g/ → [ŋ]

In some cases subsequent P-rules may apply to alter these final non-vowels.

So, for Schachter & Fromkin (idem), it is their true consonants /p, t, k, b, d, g/ that occur at word-final position in Akan in phonological representations. Since “the glottal stop is not part of the consonant system of Akan” (Dolphyne 1988, Eshun 1993) I will not discuss its distribution in this paper. However, I will look closely at the phonological analysis of each of the four word-final consonants found in Akan in turns.

### 3. Word-final /n/

Let us begin by studying the following data.

(1) UR	Fante	Akuapem	Asante	English
a. sinĩ	s <sup>ɲ</sup> ĩn	s <sup>ɲ</sup> ĩŋ	s <sup>ɲ</sup> ĩĩ	‘not full, short’
b. dmiĩ	d <sup>z</sup> ĩn	d <sup>ɲ</sup> ĩŋ	d <sup>ɲ</sup> ĩĩ	‘strong, hard, difficult’
c. punũ	p <sup>w</sup> ũn	p <sup>w</sup> ũŋ	p <sup>w</sup> ũũ	‘to smoke a pot’
d. hunũ	h <sup>w</sup> ũn	h <sup>w</sup> ũŋ	h <sup>w</sup> ũũ	‘to swell’
e. fɔnũ	f <sup>v</sup> ũn	f <sup>v</sup> ũŋ	f <sup>v</sup> ũũ	‘to be emaciated’
f. tɕɛnĩ	tɕɛn	tɕɛŋ	tɕɛĩ	‘to wait’
g. kanĩ	kān	kaŋ	kāĩ	‘to count’

Following Dolphyne (1965) and Schachter & Fromkin (1968) I analyzed a similar data in Abakah (1978:29-30) and argued that in Akan, the final N of a CVN structure has two realizations. In all the dialects one of these realizations is a bilabial nasal [m] as in [dam] ‘madness’. The second realization of N is different in each of the three major dialects. It is a velar nasal [ŋ] in Akuapem but an alveolar nasal [n] in Fante. In Asante, such syllables are pronounced with a glide towards nasalized close back vowels [u] or [ʊ] if the vowel in the structure is back. However, if the syllable vocalism is non-back, there is a glide towards nasalized close front vowels [i] or [ɪ]. The choice between [u] or [ʊ] and [i] or [ɪ], respectively, is determined by whether the preceding vowel is advanced or unadvanced.

Abakah (1978) is more descriptive than analytic. However, since then it is only Dolphyne (1988) who has studied word-final consonants in Akan and her analysis of the Asante output forms is quite different from the analysis in Dolphyne (1965), which I have referred to above. Dolphyne (1988: 109) has argued that in Asante

Where the stem has CVn form, it is pronounced with a tongue movement from the vowel sound towards a palatal nasal [ɲ] or a labialized velar nasal [ŋw] depending on whether the vowel is front or back respectively. This final nasal consonant position may not be reached where the vowel of the stem is a non-high vowel, so that the stem may end in a nasalized high vowel.<sup>1</sup>

The following are included in the examples she has given to illustrate her point.

- (2) a. kan: kãɲ / kãĩ 'read'  
 b. dīn: dīɲ / dīĩ 'name'  
 c. sɛn: sɛɲ / sɛĩ 'how much'  
 d. tɔn: tɔɲ<sup>w</sup> / tɔũ 'sell'  
 e. hun: hũɲ<sup>w</sup> / hũũ 'swell'  
 f. bɪn: bĩɲ / bĩĩ 'be cooked'

Though very plausible, we think that the motivation for this sort of analysis is lacking in that throughout the Akan phonology, apart from Fante, [n] does not undergo any process of palatalization in either Asante or Akuapem in the context before of a palatal vowel. It is therefore counterintuitive to analyze the Asante output forms in question as emerging as a result of palatalization.

(3)	<b>UR</b>	<b>Fante</b>	<b>Akuapem/Asante</b>	<b>English</b>
a.	animu	ejĩm	anjĩm	'face'
b.	ni	ɲĩ	nĩ	'and'
c.	onini	oɲĩn	onĩnĩ	'python'
d.	tɛɪɪɛɪɪɛ + ni <sup>2</sup>	tɛɪɪɛɪɪɛɲĩ	tɛɪɪɛɪɪɛnĩ	'teacher'

It is equally counterintuitive to analyze the Asante output forms in (1c-d) above as [ŋw]-final. I do not see the motivation for the backness and the roundness of the final N in Dolphyne's data in question. Dolphyne (*idem*) does not make it clear whether the process of N-backness and roundness is perseverative or anticipatory. Since her data does not contain back vowels following the N, I assume that Dolphyne (*idem*) has tacitly referred to her process of N-backness and roundness as being perseverative. If this assumption of mine were right then it would indeed be a unique process. This is because, so far any process of labialization that I have ever encountered in Akan is anticipatory rather than perseverative. It is worth stating

<sup>1</sup> Dolphyne's (1988) use of <ɛ> and <ny> correspond to the IPA symbols <ɪ> and <ɲ>, respectively. I will use the IPA symbols when using her examples.

<sup>2</sup> Comprised of 'to teach' + a person/agentive-suffix.

that this assumption is not right inasmuch as Dolphyne (p.c) analyzes any word-final consonant in Akan as phonetic but a penult in phonological representations. In line with my present analysis, I prefer Dolphyne’s (1965) analysis of word-final consonants in Akan to that of Dolphyne (1988) by reason of the fact that the former is more elegant and illuminating.

### 3.1 Discussion

To begin with, Schachter & Fromkin (1968) have analyzed word-final consonants in Akan and in their analysis, they posit stop consonants at the lexical level of representation as I have already noted in §2.1. Schachter & Fromkin (idem) argue that:

At the systematic-phonemic level, morpheme-final non-vowels are restricted ... to the six top consonants /p, t, k, b, d, g/

They argue further that phonological (P)-rules later apply to transform these stop consonants into their respective/desirable word-final consonants. I reproduce some of their P-rules regarding syllbale-final consonants as (4):

(4) a. P(ii) (P03)

$$\left[ +\text{Consonantal} \right] \rightarrow \left\{ \begin{array}{l} \left[ +\text{Nasal} \right] / \left[ \begin{array}{c} \text{---} \\ +\text{Voiced} \end{array} \right] \\ \left[ +\text{Voice} \right] / \left[ \begin{array}{c} \text{---} \\ +\text{Anterior} \\ -\text{Nasal} \end{array} \right] \\ \left[ \begin{array}{c} +\text{Consonantal} \\ <+\text{Glottalic}> \end{array} \right] / \left[ \begin{array}{c} \text{---} \\ <+\text{Anterior}> \\ -\text{Nasal} \end{array} \right] \\ \left[ +\text{Vocalic} \right] / \left[ \begin{array}{c} +\text{Coronal} \\ -\text{Nasal} \end{array} \right] \end{array} \right\} / \text{---} =$$

## b. P(iii) (P70)

$$\begin{array}{l}
 [\eta] \quad \rightarrow \quad [n] \\
 [\eta] \quad \rightarrow \quad [n] / \_ \quad \left\{ \begin{array}{l} (+) V \\ (\uparrow) \#\# \end{array} \right\} \begin{array}{l} : \text{As} - \text{Fa} \\ : \text{Fa} \end{array}
 \end{array}$$

c. P(iv) (P71):  $[\eta(\uparrow)]$  VOCALIZATION

$$(a) \quad [\uparrow] \quad \rightarrow \quad \emptyset / [\eta] - \#\# : \text{As}$$

$$(b) \quad [\eta] \quad \rightarrow \quad \left[ \begin{array}{l} +\text{Vocalic} \\ \alpha\text{Back} \\ \beta\text{Tense} \end{array} \right] / \left[ \begin{array}{l} +\text{Vocalic} \\ \alpha\text{Back} \\ \beta\text{Tense} \end{array} \right] \_ \#\# : \text{As}$$

P(ii), for instance, changes syllable-final /b, d, g/ to [m, n, ŋ] respectively. P(iii) changes word-final [ŋ] to [n] in Fante while P(iv) changes word-final [ŋ] to a nasalized high vowel in Asante. I agree with Schachter & Fromkin (*idem*) for giving a common underlying segment for all the Akan dialects at the word-final position but I differ in terms of the types of segment posited. If Akan had no underlying nasal segments, then positing underlying /g/ would not present an embarrassing problem within the framework of their analysis above. The above analysis of Schachter & Fromkin's (1968) is hardly illuminating. It clearly proves further the inability of the linear approach to capture phonological processes elegantly.

I wish to draw attention to the fact that Schachter & Fromkin's (*idem*) derivation of all the surface nasal consonants in Akan from oral voiced plosives as I have noted above implies that all the C<sub>2</sub>'s of their underlying CVC stems are redundantly [-Nasal]. I note that the vowels of two of Schachter & Fromkin's (1968) underlying CVC examples are prelinked to the [-Nasal] autosegment yet they have derived CVN at surface level. I present these examples as (5).

$$(5) \quad \begin{array}{l} /s\epsilon g/ \quad \rightarrow \quad [s\epsilon\eta] \\ /p\text{ɔ}g=k\text{ɔ}/ \rightarrow \quad [p\text{ɔ}\eta k\text{ɔ}] \end{array}$$

It is very important to note that mid vowels in Akan are inherently [-Nasal]. See Dolphyne (1965, 1988), Stewart (1962), Cahill (1985), Obeng (1987), Abakah (1993, 2002, In preparation) and others for a detailed study of the prelinking of the mid vowel in Akan to the [-Nasal] autosegment. Quite paradoxically Schachter &

Fromkin (idem) are also of the view that in phonological representations, mid vowels in Akan redundantly have [-Nasal] specification in their feature geometry. Schachter & Fromkin (idem 32) have captured this fact in their Segment Structure Condition (SgSC) 5 which I quote here as 5'.

$$(5') \quad \text{SgSC 5} \quad \text{If:} \quad \left[ \begin{array}{c} +\text{Vocalic} \\ -\text{High} \\ -\text{Low} \end{array} \right] \\ \quad \quad \quad \quad \quad \quad \quad \quad \quad \quad \quad \quad \quad \quad \quad \downarrow \\ \quad \quad \quad \quad \quad \quad \quad \quad \quad \text{Then:} \quad \left[ -\text{Nasal} \right]$$

Schachter & Fromkin (idem) explain the above Segment Structure Condition in their own words as follows:

This condition states that the mid vowels /ε, e, ə, o/ are intrinsically non-nasal. Phonetically, when they precede a nasal segment, the velum may lower during the articulation of the vowel; phonologically, there are no morphemes which are distinguished by contrasts between nasal and oral vowels of this sort.

It therefore comes as a big surprise that their derived outputs in (5) have nasal consonants at either syllable or word-final position despite the fact that not even one of the consonantal melodies contained in their underlying representations in (5) can be specified as [+Nasal]. I, really, am unable to fathom the justification for deriving nasality from a consonant prespecified for the feature [-Nasal]. The fact is, there is no morpheme in Akan that is consonant-final at the systematic phonemic level and, for this reason, any analysis that posits an underlying consonant as a morpheme-final consonant starts on a faulty note.

In his study of word-final consonants in Akan, Eshun (1993) has also posited /m/ and /n/ as the underlying consonantal segments. As regards the occurrence of word-final /n/, /ŋ/ and the nasalized high vowel, in Fante, Akuapem and Asante respectively, Eshun (idem) posits /n/ as the underlying consonant for all the Akan dialects. He then formulates P-rules to generate the Akuapem and the Asante phonetic representations. He argues that strong motivation for deriving the Asante final vowel from an underlying nasal consonant is provided by English loanwords that are nasal-final. He presents the following data (idem:157) reproduced here as (6).

(6) i) English final [m]

<b>Fante</b>	<b>Akuapem</b>	<b>Asante</b>	<b>English</b>
[fããm]	[fããm]	[fããm]	‘farm’
[firĩm]	[firĩm]	[firĩm]	‘film’
[bããm]	[bããm]	[bããm]	‘balm’

ii) English final [n]

<b>Fante</b>	<b>Akuapem</b>	<b>Asante</b>	<b>English</b>
[pʰẽn]	[pẽŋ]	[pẽĩ]	‘pen’
[pʰĩn]	[pĩŋ]	[pĩĩ]	‘pin’
[mããn]	[mãŋ]	[mãĩ]	‘man’

iii) English final [ŋ]

<b>Fante</b>	<b>Akuapem</b>	<b>Asante</b>	<b>English</b>
[kĩĩn]	[kĩŋ]	[kĩĩ]	‘kin’
[paakĩn]	[paakĩŋ]	[paakĩĩ]	‘parking’
[tĩn]	[tĩŋ]	[tĩĩ]	‘thing’

Eshun (*idem*) summarizes the above data as follows:

- In set (i), English word-final [m] is realized as [m] across-the-board.
- In set (ii), English word-final [n] is realized as [n] in Fante, [ŋ] in Akuapem and a nasalized vowel in Asante.
- In set (iii), English word-final [ŋ] is realized as [n] in Fante, [ŋ] in Akuapem and a nasalized high vowel in Asante, showing the same distribution as in set (ii).

According to Eshun (*idem*), this provides a further argument against setting up /ŋ/ as an additional underlying form in Akan because /n/ adequately represents the whole lot. It also provides a strong motivation for analyzing the Asante word-final vowels as alternations of underlying /n/. Moreover, it would also make for a more elegant analysis not to set up different underlying representations for each of the dialects but to derive the surface forms from one underlying representation in support of the fact that these are dialects of one language.

Our only problem with Eshun’s (*idem*) analysis resides in the fact that he has set up /n/ as an underlying word-final consonant and not as a penult. However, I posit /n/ as an underlying penultimate consonant in Akan in spite of the fact that

each dialect realizes it (as an ultimate consonant) differently at the surface level. This is clearly specified in our underlying forms in (1). Various dialect-specific rules then apply to the underlying form to generate the various dialect-particular surface forms. Looking at (1), for example, Fante and Akuapem delete the final [+High] vowel whereas Asante retains it (the final high vowel). Asante on the other hand, deletes the nasal consonant but Fante and Akuapem retain it but in diverse C-Place articulation features, [CORONAL] in Fante, and [DORSAL] in Akuapem. I summarize the various rules, which apply to the underlying representation to yield the derived output in the various dialects in the derivational constituents of (7).

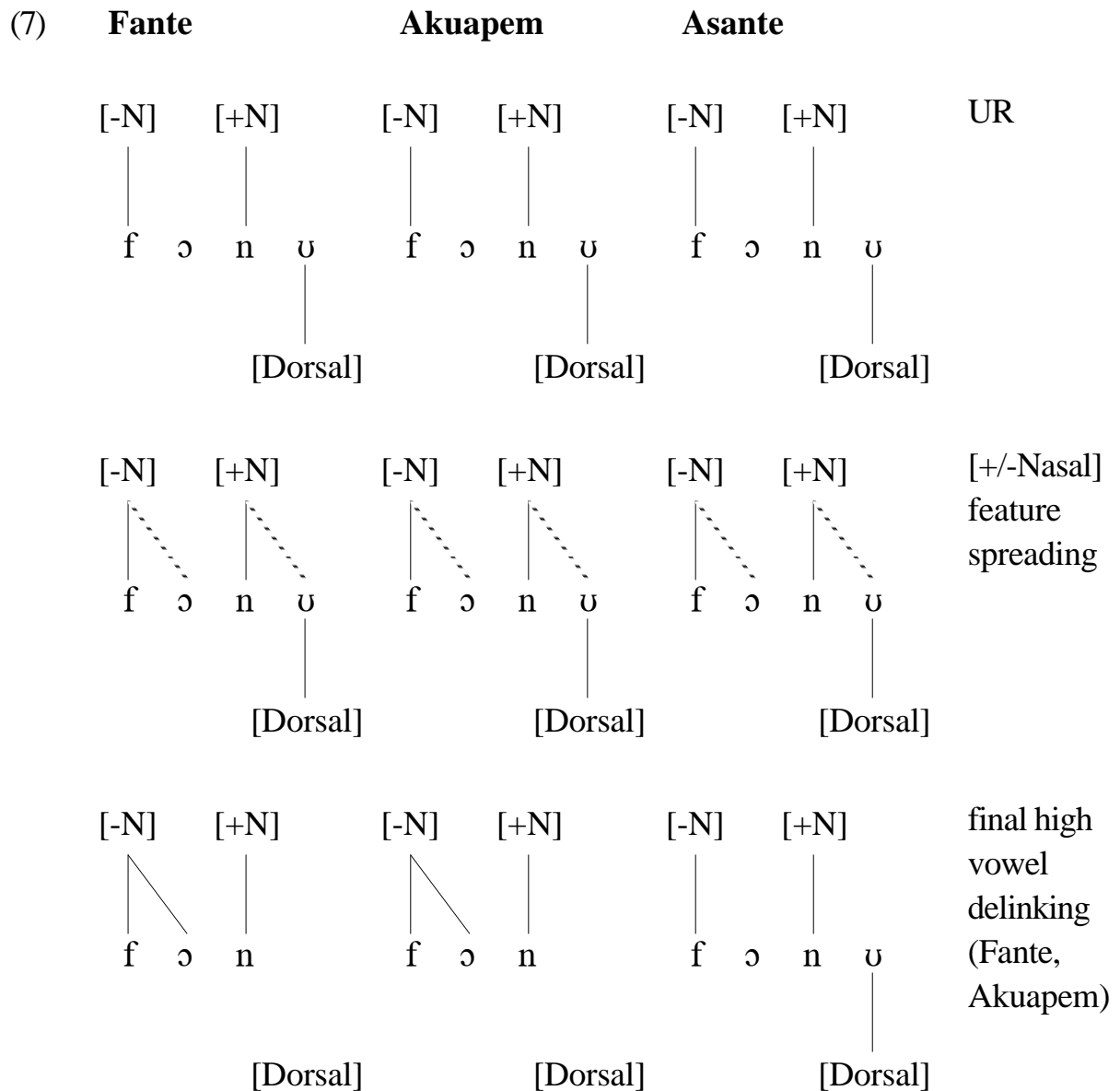

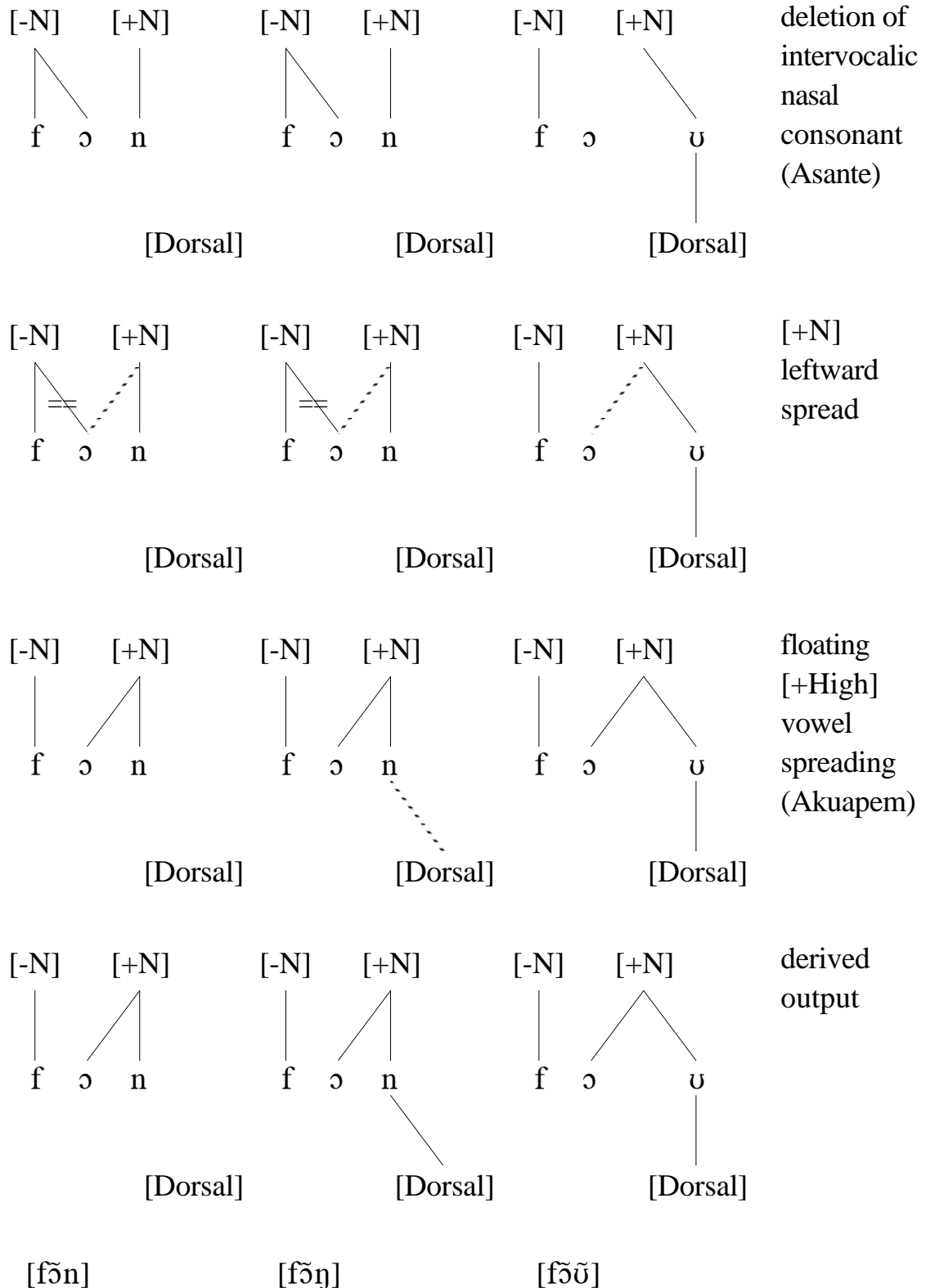

From the set of rules captured by the above derivations, I realize that the vocalic segments in all the three main dialects of Akan are unspecified for the [+/-Nasal] feature. Thus the consonants spread their inherent [+/-Nasal] feature specification to the following vowels. In Fante and Akuapem, the word-final vowel then delinks from the [DORSAL] autosegment and floats accordingly. Next, the [+Nasal]

autosegment spreads to the preceding [-Nasal] vowel in both Fante and Akuapem to yield the phonetic stage in Fante. In Akuapem, the floating [DORSAL] autosegment docks to the *new* word-final /n/, causing its place of articulation feature to change from [CORONAL] to [DORSAL]. In Asante, after the consonantal segments of the morpheme have spread their [-Nasal] feature rightwards to the adjacent vowels in (b), the intervocalic /n/ deletes as in (e) causing the oral /ɔ/ and the nasalized /ũ/ to occur contiguously. This sort of vowel sequence is unattested in Akan like almost every known language in the world without the [+Nasal] vowel spreading either anticipatorily or perseveratively to the adjacent [-Nasal] vowel. Here, the [+Nasal] value of the word-final vowel spreads leftwards to the preceding [-Nasal] vowel to generate the derived output.

### 3.1.1 Exceptions

In the Akuapem and the Asante dialects these rules are not consistently adhered to, while Fante invariably applies them whenever the required conditions are satisfied. Consider the following data.

(8) UR	Fante	Akuapem	Asante	English
a. bɔni	b <sup>w</sup> ɔ̃n	b <sup>w</sup> ɔnĩ	b <sup>w</sup> ɔnĩ	‘sin/bad’
b. húnú	hún	hún	hún	‘to swell’
c. húnú	hún	hún	hún	‘to dissolve’
d. ɔsunũ	ɔsun	ɔsun	ɔsun	‘elephant’
e. pini	pĩn	pĩn	pĩn	‘to agree’
f. tɛmi	tɛm	tɛm	tɛmĩ	‘drum’
g. mini	mĩn	mĩn	mĩn	‘to swallow’

In the above data, it is realized that Fante consistently applies the set of rules while in the Akuapem and the Asante examples the first step of the set of rules, identified above, constitutes the terminal stage. What makes the situation a bit complicated is, there is no systematic way of non-applicability of the rules in question. In (8a), for instance, if the set of rules in question applied in Asante, a phonetic form, \*[bɔ̃ĩ], which is nonexistent/unattested in the dialect would be generated. But there is no argument to put forth in defence of the non-applicability of the rules in the Akuapem counterpart, which is identical to the Asante form. The inconsistencies associated with the Akuapem and Asante dialects are clearly exhibited by (8b) and (8c) whereby both morphemes, having identical segmental and tone melodies, are realized on the same tone melody yet one (8b) applies the rules while the other (8c) does not. These apparent exceptions are not widespread in the dialects in question. They are very minimal.

#### 4. Word-final /m/

Labial /m/ occurs at word-final position in all the dialects of Akan as illustrated in the following data:

(9) UR	Fante	Akuapem	Asante	English
a. adumu	ad <sup>w</sup> ũm	ad <sup>w</sup> ũm	ad <sup>w</sup> ũm	‘grace’
b. kumu	k <sup>w</sup> ũm	k <sup>w</sup> ũm	k <sup>w</sup> ũm	‘to kill’
c. sumu	s <sup>w</sup> ũm	s <sup>w</sup> ũm	s <sup>w</sup> ũm	‘to serve’
d. tamu	tãm	tam	tam	‘to lift up something’
e. timi	t <sup>s</sup> ĩm	t <sup>ɥ</sup> ĩm	t <sup>ɥ</sup> ĩm	‘be stuck (to the ground)’
f. pimu	p <sup>ɥ</sup> ĩm	pĩm	pĩm	‘to hit’

Like the case of /n/ above, Fante shows consistency while in Akuapem and Asante there are few cases where the phonetic representations and the underlying representations are identical because the high vowel which the nasal consonant precedes is preserved in the output. The examples in (10) illustrate this point.

(10) UR	Fante	Akuapem	Asante	English
a. tumi	t <sup>w</sup> ũm	t <sup>w</sup> umĩ	t <sup>w</sup> umĩ	‘power’
b. humi	h <sup>w</sup> ũm	h <sup>w</sup> umĩ	h <sup>w</sup> umĩ	‘breathe’
c. pamu	pãm	pam	pam	‘sew’
d. pamu	pãm	pam/pamũ	pam/pamũ	‘chase’
e. jami	jãmĩ	jãmĩ	jãmĩ	‘God’

Comparison of (8b-d) with (10c-d) reveals that [h<sup>ɥ</sup>ũj/h<sup>ɥ</sup>ũn<sup>ɥ</sup>] (Ak) and [h<sup>ɥ</sup>ũj/h<sup>ɥ</sup>ũn<sup>ɥ</sup>] (As.) ‘to swell/to dissolve’ behave phonologically the same as the Asante/Akuapem [pam/pamũ] ‘to sew/to chase’ examples. It is realized that here, too, the Asante and the Akuapem phonetic representations exhibit some inconsistency. Whereas the word for ‘sew’ in Akuapem and Asante is /m/-final the one for ‘chase’ is either /ʉ/- or /m/-final. The two forms are used interchangeably. Fante shows consistency in the application of the set of phonological rules referred to above. However, there are so far only two words, [jãmĩ] ‘God’, example (10e) and [kwamĩ] ‘name of a male’ to which the rule of post-sonorant final high vowel deletion rule does not apply in Fante.

## 5. Liquid /r~l/

Liquids [r] and [l], being free variants, occur word-finally in Fante only as examples in (11) demonstrate. In the other dialects of Akan, either the whole lexical final -CV# syllable of which [r] or [l] constitutes the C is either deleted or retained at the surface level as illustrated by the examples in data (11) and (12).

(11) UR	Fante	Akuapem	Asante	English
a. firi	f <sup>h</sup> ir	firi/fri	firi/fri	‘to geminate’
b. huru	ɬur	h <sup>w</sup> ur <sup>w</sup> ɔ/h <sup>w</sup> r <sup>w</sup> ɔ	h <sup>w</sup> ur <sup>w</sup> ɔ/h <sup>w</sup> r <sup>w</sup> ɔ	‘wash’
c. duru	d <sup>w</sup> ur	d <sup>w</sup> ur <sup>w</sup> u/d <sup>w</sup> r <sup>w</sup> u	d <sup>w</sup> ur <sup>w</sup> u/d <sup>w</sup> r <sup>w</sup> u	‘heavy’
d. piri	p <sup>h</sup> ir	piri/pri	piri/pri	‘struggle’
e. suru	s <sup>w</sup> ur	s <sup>w</sup> ur <sup>w</sup> ɔ/s <sup>w</sup> r <sup>w</sup> ɔ	s <sup>w</sup> ur <sup>w</sup> ɔ/s <sup>w</sup> r <sup>w</sup> ɔ	‘heavens’

(12) UR	Fante	Akuapem	Asante	English
a. ferɪ	f <sup>h</sup> er	ferɪ	ferɪ	‘be embarrassed’
b. tɕerɪ	tɕer	tɕerɪ/tɕɛ	tɕerɪ/tɕɛ	‘to delay’
c. warɪ	war	warɪ/wa	warɪ/wa	‘be long/tall’
d. dɔrɪ	d <sup>w</sup> ɔr	d <sup>w</sup> ɔrɪ/d <sup>w</sup> ɔ	d <sup>w</sup> ɔrɪ/d <sup>w</sup> ɔ	‘be fat’
e. pɔrɪ	p <sup>w</sup> ɔr	p <sup>w</sup> ɔrɪ/p <sup>w</sup> ɔ	p <sup>w</sup> ɔrɪ/p <sup>w</sup> ɔ	‘bleach skin’
f. porɪ	p <sup>w</sup> or	p <sup>w</sup> orɪ	p <sup>w</sup> orɪ	‘to snub’

In (11), [r], as an underlying penult, occurs intervocalically and the vowels between which it occurs are necessarily specified as [+High]. In this scenario, Akuapem and Asante either retain all the underlying segmental sounds at the phonetic surface or the Pre-[r] high vowel is deleted. Akuapem and Asante speakers use these two output forms interchangeably. In (12), the pre-[r] high vowels are nonhigh and for this reason they do not meet the requirements for deletion. Thus, the Akuapem and the Asante output forms either delete both the intervocalic [r] and the word-final high vowel, that is, the entire final (CV) syllable of the word or retain the input form at the output level. Here, too, not all words can have the final -CV# syllable deleted in Asante and Akuapem as the examples in (12) show. Fante consistently deletes the final high vowel provided it is specified as [+High].

## 6. Word-Final /W/

Schachter & Fromkin (1968) derive the word-final [w] from an underlying morpheme-final [p] in Akuapem and Fante. They argue that in Asante however, a

morpheme-final [w] “is replaced by a glottal stop by means of the following P-rule”, here reproduced as (13):

$$(13) \quad P_x (P29): \quad [w] \rightarrow [\text{ʔ}] / - + \text{As}, \text{Fa}^2$$

Schachter & Fromkin (*idem*) argue further that “this rule is responsible for such dialect differences Ak-Fa<sup>1</sup> [sawʔ]/As-Fa<sup>2</sup> [saʔ] ‘dance’, Ak-Fa<sup>1</sup> [piwʔ]/As-Fa<sup>2</sup> [piʔ] ‘be thick’, Ak-Fa<sup>1</sup> [dɔwʔ]/As-Fa<sup>2</sup> [dɔʔ] ‘to cultivate’ ” etc.<sup>3</sup> Schachter & Fromkin’s (*idem*) analysis fails to capture the true state of affairs, which I present shortly.

Eshun (1993) has also proposed /w/ as a word-final consonant for all the dialects of Akan. He formulates the following rule, reproduced here as (14), which deletes the word-final /w/ in the Asante forms at the output level.

$$(14) \quad \left[ \begin{array}{c} \text{C} \\ +\text{High} \\ +\text{Cont} \\ -\text{Ant} \end{array} \right] \rightarrow \emptyset / - \#$$

Eshun’s (*idem*) analysis is preferable to that of Schachter & Fromkin; at least his underlying form is not chaotically abstract and above all his “phonological rule and representation bear a direct relation to surface linguistic form” (Hooper 1976: xii). However, I have a problem with Eshun’s (*idem*) failure to derive the morpheme-final /w/ from an underlying CVwV form, which constitutes the natural underlying form. It is the natural underlying form because in Akan, when any unit of utterance is suffixed to a morpheme that ends in /w/ in phonetic representation, the underlying form is retained at the phonetic stage. For example, /wɔ+hawɔ+mi/ ‘you worry/trouble me’ becomes [ɪhawɔm] in Fante, [wɔhawɔmi] in Akuapem and [wɔhami] in Asante. In these examples the fact that surface /w/ in Akan is underlyingly a penult manifests itself in the Fante and the Akuapem phonetic representations. Above all, the theoretical framework of linear phonology within which Eshun (*idem*) carried out his analysis is incapable of capturing the process in an elegant way.

I posit an underlying high vowel at the final positions in words that terminate in /w/ at the phonetic surface in Akan. This final high vowel deletes in the course of

<sup>3</sup> Schachter & Fromkin (1968) do not explain the varieties of Fante, which they refer to as Fa<sup>1</sup> and Fa<sup>2</sup>. However, it is transparently obvious that Fa<sup>1</sup> and Fante<sup>2</sup> are synonymous with the Fante sub-dialects Iguae and the Boka, respectively. For a classification of Fante dialects, see Abakah (1998, 2002).

derivation, leaving the /w/ as a word-final syllabic glide. Hence, there is no underlying word-final consonant in Akan, contrary to Eshun’s (1993) and others’ analyses. Like any other word-final consonantal sonorant in Akan, /w/ does not occur word-finally in phonological representations but in phonetic representations only.

(15) UR	Fante	Akuapem	Asante	English
a. tɕɛwɔ	tɕɛw	tɕɛw	tɕɛ	‘hat’
b. fɛwɔ	fɛw	fɛw	fɛ	‘beautiful’
c. tuwɔ	tuw	tuw	tu	‘be proud/haughty’
d. siwɔ	siw	siw	si	‘to pound’

It is discernible from (15) that the occurrence of /w/ at word-final position in Akan is essentially restricted to the Fante and Akuapem dialects. In regard to words in which /w/ occurs at word-final position in phonetic representations, Asante deletes the whole word-final -SV# syllable as the examples in (15) illustrate, while Fante and Akuapem delete only the underlying postsonorant word-final high vowel.

The above examples are representative of words that end in /w/ at the surface level. The derivations in (16) capture the processes by which /w/ emerges at the surface level in the various dialects of Akan.

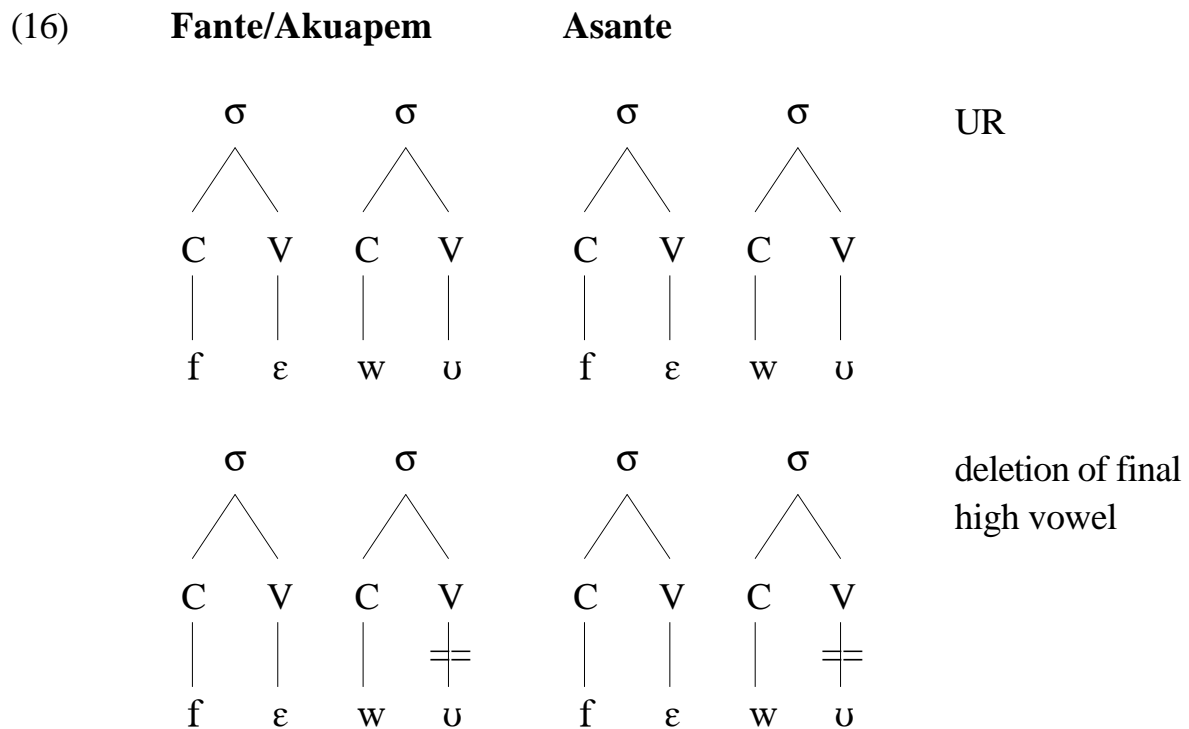

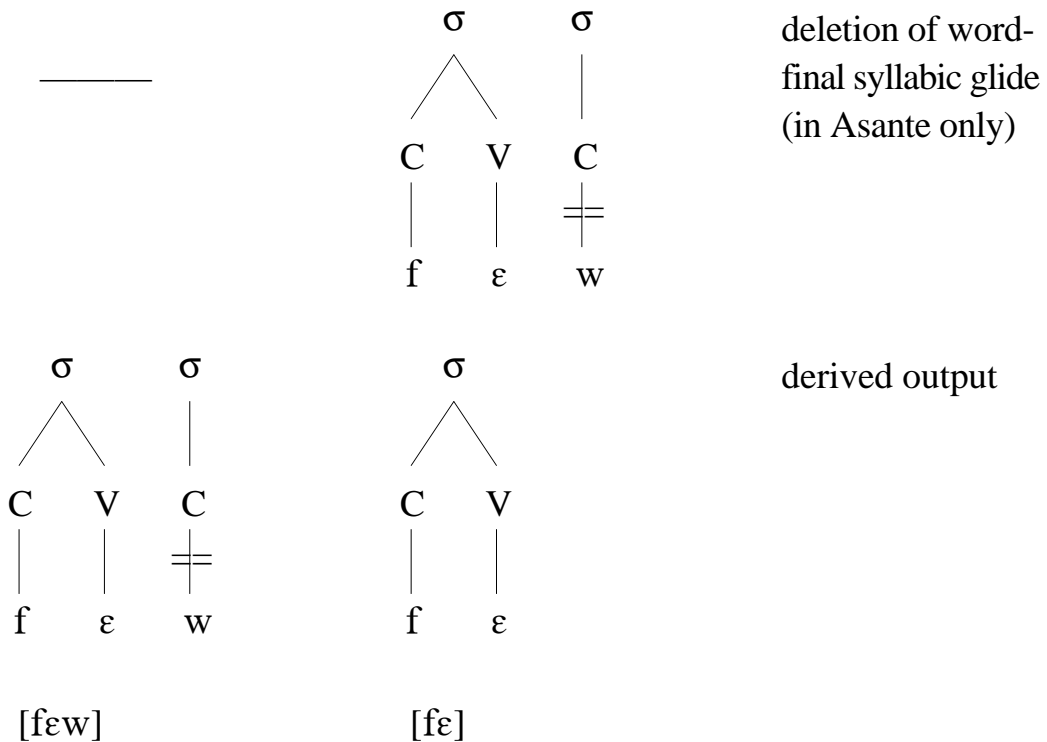

The above derivations make it evident that when the word-final high vowel deletes in all the dialects of Akan Asante extends the deletion process to the resultant new word-final segment. In other words, while the deletion process terminates on the postsonorant final high vowel in Fante and Akuapem, Asante goes a step further to apply a deletion rule to delink the resultant final /w/ from the CV-tier, thereby deleting the entire word-final syllable. On the other hand, it is observed that /w/ does occur word-finally in a few words in Asante. The following illustrative examples are the only words contained in (and extracted from) the corpus of our data in which phonetic, word-final /w/, is attested in Asante. See also Dolphyne (1988).

- (17)      a. [tɕɛw] as in a phrasal verb [pa tɕɛw]      ‘to apologize’  
             b. [ɔhaw]    ‘trouble’  
             c. [jaw]    ‘Yaw (name)’

## 7. Conclusion

The discussion in this article has made it unambiguous that Akan has 4 consonants that occur word finally, and that these consonants are all sonorants and not obstruents as Schachter & Fromkin (1968) and some other scholars claim. I have given adequate evidence to demonstrate in this article that each of the four word-final sonorants in Akan occurs in phonological representations as a penult, and that when a high vowel follows it, the high vowel deletes causing the penultimate consonantal sonorant to appear at the phonetic surface as a word-final consonant. I

have also established the fact that while the elision of post-sonorant word-final high vowel applies obligatorily in Fante, regardless of the quality of the penultimate consonantal sonorant, Akuapem puts the elision process in question on hold when the sonorant in question is /r/. It is highly discernible from the discussion that Asante does not often observe this elision process. As a result, it is only when the consonantal sonorant penult is /m/ that the rule of post-sonorant final high vowel deletion applies in Asante.

## LIST OF ABBREVIATIONS AND SYMBOLS

α	[+/-]
Ak.	Akuapem, a dialect of Akan
As.	Asante, a dialect of Akan
C	Consonant
CV	A syllable that has the structure Consonant-Vowel
CVC	A word that has the structure Consonant-Vowel-Consonant
CVN	A word with Consonant-Vowel-Nasal Consonant Structure
CVn	A word with Consonant-Vowel-Alveolar nasal structure
CVwV	A stem word with Consonant-Vowel-w-Consonant Structure
Fa.	Fante, a dialect of Akan
IPA	International Phonetic Alphabet
N	Nasal Consonant
[+N]	[+Nasal] (Feature)
[-N]	[-Nasal] (Feature)
P	Phonological Rule
P-Rule	Phonological Rule
SgSC	Segment Structure Condition
SqSC	Sequence Structure Condition
SV	A syllable with (Consonantal) Sonorant-Vowel Structure
-SV#	Word-final syllable with nonvowel Sonorant-Vowel Structure
UR	Underlying Representation
#	Word boundary

## REFERENCES

- Abakah, Emmanuel N. 1978. Dialect differences between Mfantse and Bɔ̀ɔ̀ɔ̀ (Nkusukum) Mfantse. Unpublished Long Essay. Department of Linguistics, University of Ghana, Legon
- . 1993. Some aspects of the phonology of the Mfantse dialect of Akan. MPhil thesis. University of Ghana, Legon.

———. 1998. On the question of standard Fante. *Journal of West African languages*, 27 (1), pp 94-115.

———. 2002. Remarks on the Akan vocalic inventory. In: *New directions in Ghanaian linguistics*, pp 243-263. Edited by Felix Ameka & E. K. Osam. Accra: Black Mask Ltd.

———. In preparation. Segmental and tone melodies of Akan. Manuscript.

Cahill, Michael. 1985. An autosegmental analysis of Akan nasality and tone. Non-thesis MA project. University of Texas at Arlington.

Clements, George N. 1985. The geometry of phonological features. *Phonology yearbook*, 2, pp 223-52.

Clements, George N.; Hume, E. V. 1995. The internal organization of speech sounds. In: *The handbook of phonological theory*, pp 245-306. Edited by John A. Goldsmith. Oxford: Blackwell.

Dolphyne, Florence A. 1965. Phonetics and phonology of the verbal piece in the Asante dialect of Twi. PhD thesis. University of London.

———. 1988. *The Akan (Twi-Fante) language: its sound system and tonal structure*. Accra: Universities of Ghana Press.

Eshun, F. B. 1993. Aspects of Akan phonology. PhD thesis. University of Wisconsin-Madison.

Gussenhoven, C.; Jacobs, H. 1998. *Understanding phonology*. Oxford University Press.

Hooper, J. B. 1976. *An introduction to Natural Generative Phonology*. New York: Academic Press.

McCarthy, John. 1988. Feature geometry and dependency: a review. *Phonetica*, 43, pp 84-108

Obeng, Samuel Gyasi. 1987. Conversational strategies: towards a phonological description of projection in Akyem Twi. DPhil thesis. University of York, UK.

Odden, David. 1991. Vowel geometry. *Phonology*, 8, pp 261-289.

Sagey, E. C. 1986. The representation of features and relations in nonlinear phonology. PhD thesis. Massachusetts Institute of Technology.

Schachter, Paul; Fromkin, Victoria. 1968. *A phonology of Akan: Akuapem, Asante and Fante*. UCLA working papers in phonetics, n 9. University of California, Los Angeles (UCLA).

Stewart, John A. 1962. An analysis of the structure of the Fante verb, with special reference to tone and glottalization. PhD thesis. University of London.